

## Carbon Dioxide Detector E2609-CO2 User Manual

### Description

Carbon Dioxide Detector E2609-CO2 is intended for air quality control and prevention of carbon dioxide accumulation to ensure the occupant's maximal comfort levels in the indoor environments.

The instrument monitors air quality, switching on ventilation systems or safety devices as soon as potentially uncomfortable CO<sub>2</sub> concentration levels are detected. The E2609-CO2 also provides a linearized analog output of 0 – 10 V, proportional to CO<sub>2</sub> concentrations of 0 – 2000 ppm (by default) and RS485 Modbus digital communication.

This gas detector implements the low cost and maintenance-free K-30 CO<sub>2</sub> sensor, which is based on non-dispersive infrared (NDIR) waveguide technology with ABC automatic background calibration algorithm.

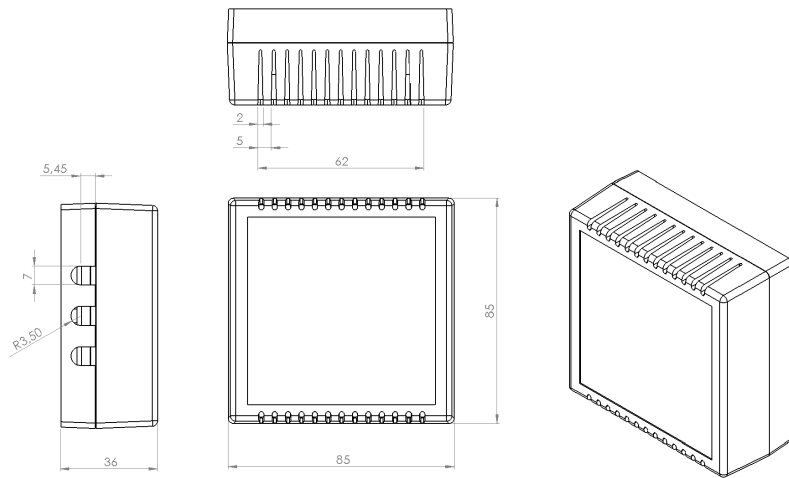

### Installation

The gas detector should be mounted on a wall not in the direct vicinity of a potential gas source or ventilation openings. The mounting height should be approximately at breathing level (ca 1,5 m from the floor). The cables should be compactly placed and if necessary, bound together, to ensure user safety.

Remove the lid and fix the detector with 2...4 screws on a wall. Connect terminal 5 to the positive terminal of 24 VDC source and terminal 2 to ground and the negative terminal of 24 VDC source. If using a secondary device, connect its input to the detector's analog output (0-10 V referenced to ground) via terminal 1. Terminals 3 (signal A) and 4 (signal B) are for RS485 digital interface lines.

The gas detector can directly control ventilation systems and other external devices. Connect external device's power circuit through terminals 6 and 7 (relay contacts).

### Recommended gas detector location

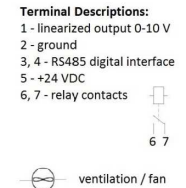
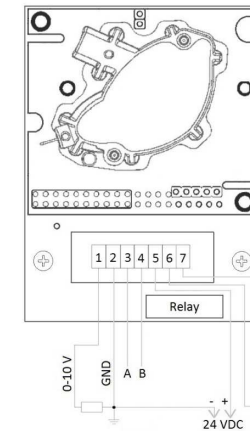
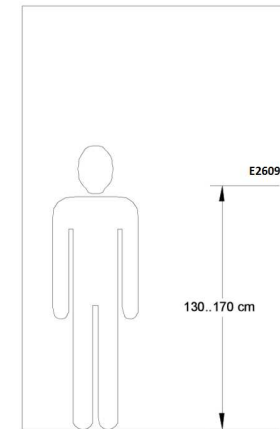

### Operation

If carbon dioxide concentration in the environment exceeds the specified value (by default 1000 ppm), the output relay contacts close, completing the external device's circuit and activating it. Relay contacts return to normal state once the concentration drops below the specified value (by default 900 ppm).

For better stability the gas detector should be powered at all times. At initial power up, the sensor may need up to a minute of warm-up time before it's readings can be trusted.

### Calibration

The CO<sub>2</sub> sensor has been pre-calibrated by the Manufacturer. This NDIR carbon dioxide sensor exhibits high stability and has a lifetime of over 15 years. No real maintenance is needed on the sensor thanks to the built-in self-correcting ABC algorithm. When checking the sensor accuracy, please note that the sensor accuracy is defined at continuous operation (at least 3 weeks after installation).

### Modbus Communication

The E2609-CO2 comes with RS485 Modbus digital interface (terminals 3 and 4). The sensor may also be communicated directly via UART when removed from the terminal PCB:

- 1) using a simple USB cable
- 2) using USB interface boards, for example a CP2101 module, connecting the USB end to an external device and TxD, RxD and GND pins to corresponding sockets on the K-30 sensor module.

Communication parameters:

Coding System.....	8-bit binary
Bits per Byte .....	1 start bit; 8 data bits, least significant bit first; No parity bits; 1 stop bit
Baud Rate .....	9600 bps

Registers and values:

Parameter	Default value	Ad- dress	Comment
Device Individual Address	104	0x00	0x68 in hexadecimal
Analog Output MaxValue	1024	0x58	10 V = 100% of 10 V = 1024/1 = 1024
Analog Output MinValue	0	0x5A	0 V = 0%
Analog Output HighCO2	20000	0x54	2000.0 ppm
Analog Output LowCO2	0	0x52	0 ppm

Addresses from 1 to 247 are reserved for slave individual addresses.

Any sensor with any individual slave address will recognise serial line PDUs with address 254 (0xFE) as addressed to them. They will respond, so this address is for production/test purposes only.

Command bytes:

Description	Value
EEPROM Read	0x46
EEPROM Write	0x43
RAM Read	0x44
RAM Write	0x41

Example for reading CO<sub>2</sub> values:

Description	Address 1-byte	Command 1-byte	Address 2-bytes	N-bytes to Read 1-byte	Checksum 2-bytes
Master transmit	0xFE	0x44	0x00 0x08	0x02	

Description	Address 1-byte	Command 1-byte	Count 1-byte	N-bytes Read n-bytes	Checksum 2-bytes
Slave reply	0xFE	0x44	0x02	0x01 0x90	

In this example, the slave responds with a CO<sub>2</sub> reading of 400 ppm (0x190 hexadecimal).

### Sensor Configuration

The sensor may also be directly configured using Modbus commands. Please note, however, that direct access to EEPROM has the ability to permanently erase your sensor's calibration. Ensure you do not write to non-documented memory locations when implementing.

Example for configuring the analog output MaxValue:

Description	Address 1-byte	Command 1-byte	Address 2-bytes	N-bytes to Write 1-byte	N-bytes Write	Checksum 2-bytes
Master transmit	0x68	0x43	0x00 0x58	0x02	0x02 0x00	

In this example, the output MaxValue is changed to 512 = 1024/2 = 50% of 10 V = 5 V (0x200 hexadecimal).

### Technical Specifications

Sensor	K30 CO2 sensor
Measurement Range	0 – 5000 ppm <sub>vol</sub> within specification, 0 – 10 000 ppm <sub>vol</sub> total CO <sub>2</sub> detection range
Sensing Method	non-dispersive infrared (NDIR) waveguide technology with ABC automatic background calibration algorithm
Sampling Method	diffusion
Maintenance Interval	no maintenance required
Self-diagnostics	complete function check of the sensor module
Warm-up Time	≤ 1 min
Output Relay	250 VAC / 30 VDC, 5 A max On/off at 1000/900 ppm CO <sub>2</sub>
Power Input	24 VDC
Power Consumption	2.0 W average, 7.2 W peak power
Analog Output	0 – 10 V linearized to 0 – 2000 ppm, configurable R <sub>OUT</sub> < 100 Ω, R <sub>LOAD</sub> > 5 kΩ
Digital Interface	RS485 Modbus RTU
Operating Temperature Range	0 to 50 °C
Operating Humidity Range	0 to 95% RH (non-condensing)
Operating Environment	residential, industrial and business indoor spaces
Housing	white ABS plastic
Dimensions	85 mm (H) x 85 mm (W) x 36 mm (D)

Default analog output 0-10V

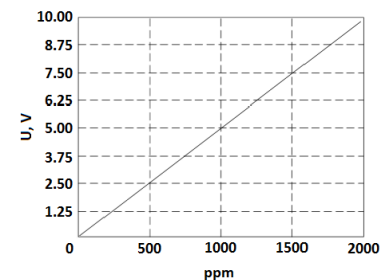

### Warranty

This product is warranted to be free from defects in material and workmanship for a period of one year from the date of original sale. During this warranty period the Manufacturer will, at its option, either repair or replace the product that proves to be defective. The warranty is void if the product has been operated in conditions not specified by the Manufacturer or damaged by customer error/negligence or if there has been an unauthorised modification.